

Stainless Steel Fittings

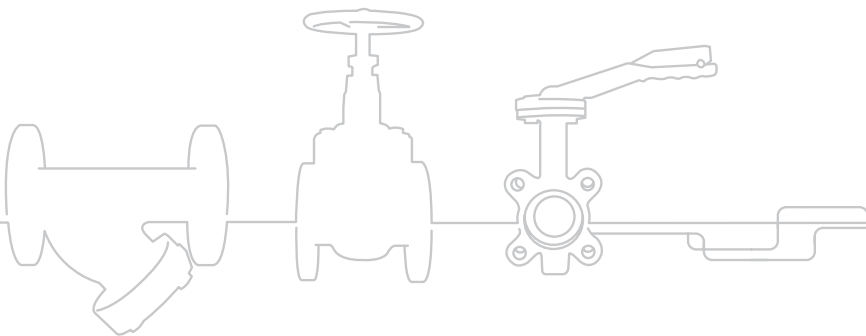

Product Information



150lb BSP Threaded Fittings General Information

- All fittings are made from CF8M (316) Stainless Steel material and conform to **ISO 4144** standard.
- All threads are to ISO 7-1 (DIN2999) BSPP Female, BSPT Male.
- Material certificates available on request.
- Pressure temperature ratings. See table below.

Temperature (°C)	Non-shock maximum working pressure (bar)
-20 to 40	20
100	16.5
150	15
200	14
220	13.5

NOTE 1 Pressure for intermediate temperatures may be determined by the interpolation method.
 NOTE 2 Temperatures indicated are those of internal fluid.
 NOTE 3 Piping loads, stresses and moments are not taken into account.

- All fittings are manufactured by investment cast process, nipples produced from welded tube.
- All items are tested & inspected prior to despatch.
- All items have a 12 month warranty from date of installation.
- All fittings manufactured in accordance with ISO9001:2008 quality system.
- CE approved
- For stocked items please consult price list

90E 90° Elbow

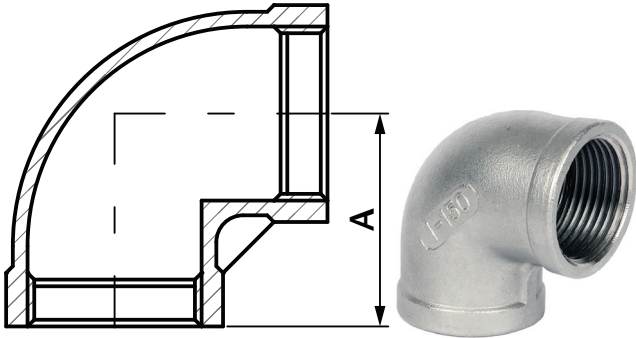

DN	A	Kgs
1/8"	17	0.020
1/4"	19	0.026
3/8"	23	0.044
1/2"	27	0.070
3/4"	32	0.108
1"	38	0.185
1 1/4"	45	0.286
1 1/2"	48	0.397
2"	57	0.518
2 1/2"	69	0.960
3"	78	1.350
4"	96	2.555

45E 45° Elbow

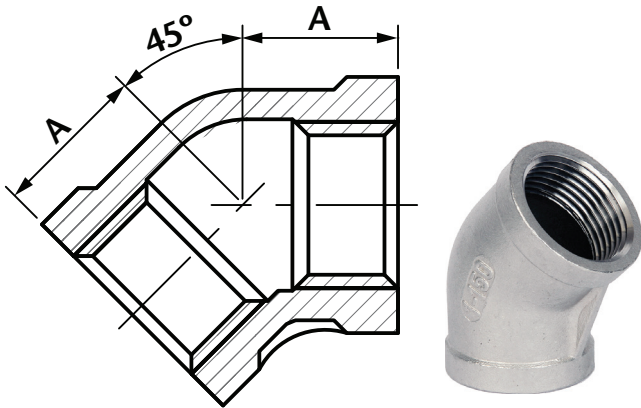

DN	A	Kgs
1/8"	17	0.020
1/4"	17	0.025
3/8"	19	0.038
1/2"	21	0.068
3/4"	25	0.096
1"	29	0.164
1 1/4"	33	0.222
1 1/2"	37	0.305
2"	42	0.460
2 1/2"	49	0.775
3"	54	1.140
4"	64	1.859

90MF 90° M/F Elbow

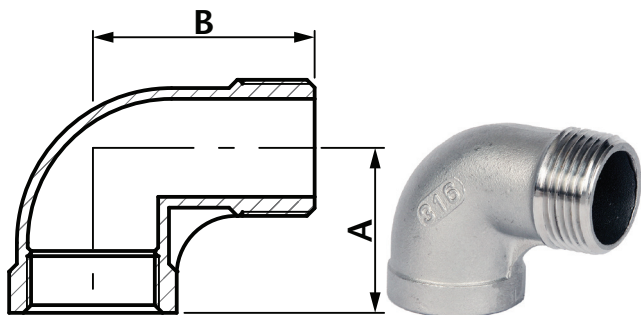

DN	A	B	Kgs
1/8"	17	26	0.020
1/4"	19	27	0.032
3/8"	23	29	0.044
1/2"	27.5	37.5	0.076
3/4"	32.5	39	0.113
1"	38	46	0.194
1 1/4"	45	54	0.270
1 1/2"	48	57	0.360
2"	57	70	0.583
2 1/2"	69	83	0.919
3"	78	94	1.583
4"	97	115	2.696

Dimensions in mm

This data sheet is designed as a guide and should not be regarded as wholly accurate in every detail. We reserve the right to amend the specification of any product without notice.

ET Equal Tee

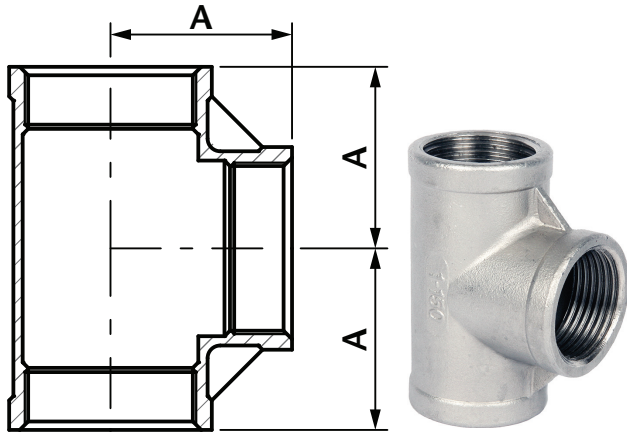

DN	A	Kgs
1/8"	17	0.028
1/4"	19	0.037
3/8"	23	0.063
1/2"	27	0.107
3/4"	32	0.158
1"	38	0.256
1 1/4"	45	0.347
1 1/2"	48	0.514
2"	57	0.685
2 1/2"	69	1.216
3"	78	1.740
4"	96	3.084

FS Full Socket OD Machined

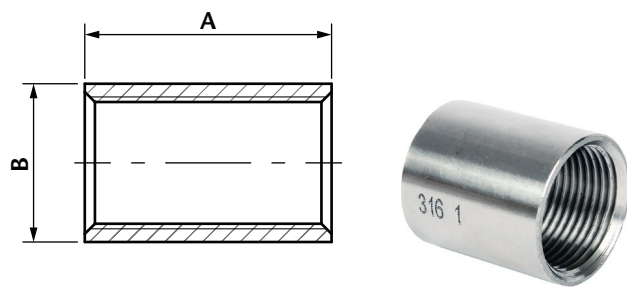

DN	A	B	Kgs
1/8"	17	13.5	0.009
1/4"	24	16.7	0.021
3/8"	25	20.4	0.029
1/2"	32	24.9	0.045
3/4"	35	30	0.057
1"	41	37.8	0.108
1 1/4"	45	47	0.165
1 1/2"	45	53	0.193
2"	54	65.7	0.315
2 1/2"	63	82	0.485
3"	69	95.8	0.709
4"	81	121.5	1.120

HS Half Socket OD Machined

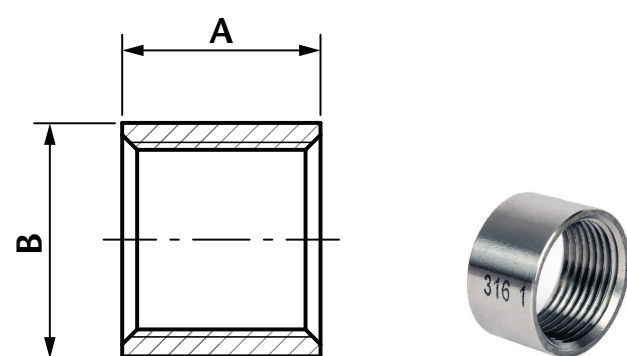

DN	A	B	Kgs
1/8"	7.5	13.5	0.005
1/4"	11	16.7	0.011
3/8"	11.5	20.4	0.014
1/2"	15	24.9	0.022
3/4"	16.5	30	0.036
1"	19.5	37.8	0.052
1 1/4"	21.5	47	0.080
1 1/2"	21.5	53	0.098
2"	26	65.7	0.152
2 1/2"	30.5	82	0.250
3"	33.5	95.8	0.367
4"	39.5	121.5	0.544

Dimensions in mm

This data sheet is designed as a guide and should not be regarded as wholly accurate in every detail. We reserve the right to amend the specification of any product without notice.

RS Reducing Socket

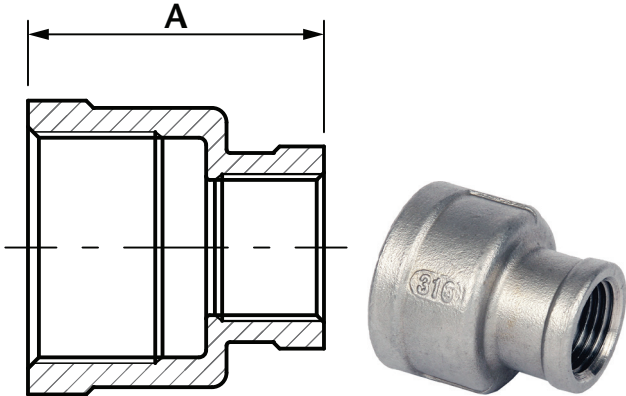

DN	A	Kgs
1/4" x 1/8"	25	0.029
3/8" x 1/4"	26	0.042
1/2" x 1/4"	34	0.051
1/2" x 3/8"	34	0.052
1/2" x 3/4"	36	0.085
1/2" x 1"	42	0.114
3/4" x 1"	42	0.136
1 1/4" x 1/2"	48	0.168
1 1/4" x 3/4"	48	0.170
1 1/4" x 1"	48	0.181
1 1/2" x 3/4"	48.5	0.225
1 1/2" x 1"	52	0.236
1 1/2" x 1 1/4"	52	0.242
2" x 1"	57.7	0.332
2" x 1 1/4"	58	0.341
2" x 1 1/2"	58	0.365
2 1/2" x 2"	65	0.567
3" x 2"	72	0.853
4" x 2"	93.8	1.655
4" x 3"	94	1.486

CSU Conical Seat Union

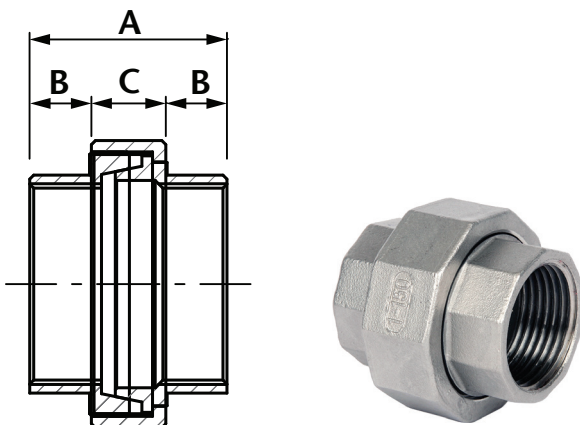

DN	A	B	C	Kgs
1/8"	30.5	8.75	13	0.059
1/4"	34	10.25	13.5	0.064
3/8"	37	10.75	15.5	0.092
1/2"	40	12	16	0.138
3/4"	43	13	17	0.206
1"	50.5	15.25	20	0.267
1 1/4"	54.5	16.25	22	0.461
1 1/2"	58	17	24	0.531
2"	65.5	19.25	27	0.834
2 1/2"	75	22.75	29.5	1.413
3"	83.5	26.25	31	1.670
4"	110.5	38.25	34	2.450

Dimensions in mm

This data sheet is designed as a guide and should not be regarded as wholly accurate in every detail. We reserve the right to amend the specification of any product without notice.

FFU

Flat Faced Union with PTFE Gasket

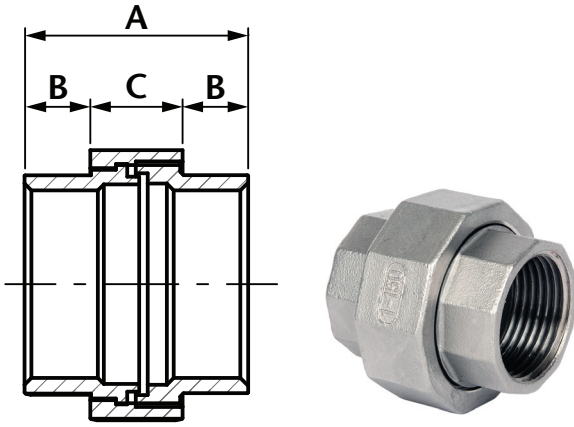

DN	A	B	C	Kgs
1/8"	30.5	8.75	13	0.055
1/4"	34	10.25	13.5	0.083
3/8"	37	10.75	15.5	0.105
1/2"	40	12	16	0.116
3/4"	43	13	17	0.198
1"	50.5	15.25	20	0.265
1 1/4"	54.5	16.25	22	0.406
1 1/2"	58	17	24	0.462
2"	65.5	19.25	27	0.684
2 1/2"	75	22.75	29.5	1.470
3"	83.5	26.25	31	1.880
4"	110.5	38.25	34	3.160

CSUMF

Conical Seat Union Male/Female

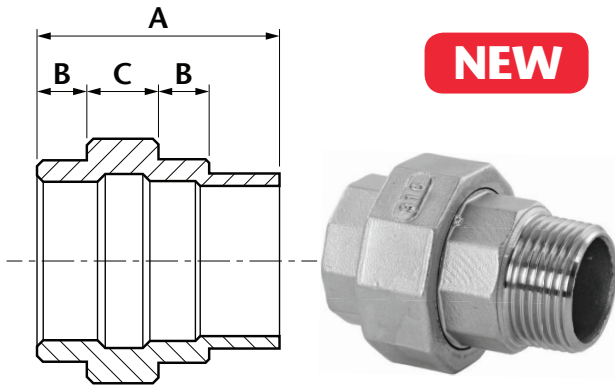

DN	A	B	C	Kgs
1/4"	44.8	10.3	13.5	0.070
3/8"	48.3	11	15	0.100
1/2"	54.8	11.9	16.3	0.155
3/4"	58.8	12.9	17.3	0.230
1"	68.8	15.1	20.3	0.310
1 1/4"	75.5	16.1	22.3	0.540
1 1/2"	79	16.9	24.2	0.605
2"	91	19.2	27.2	0.980

BN

Barrel Nipple

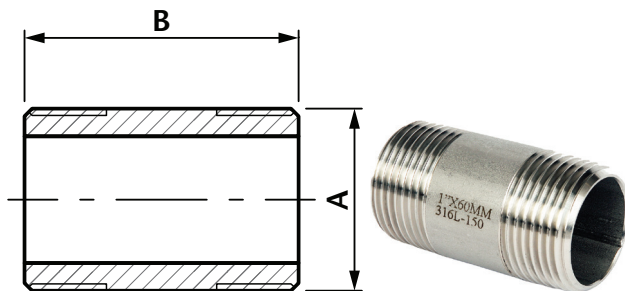

DN	A	B	Kgs
1/8"	10.2	30	0.009
1/4"	13.5	30	0.012
3/8"	17.2	40	0.024
1/2"	21.3	60	0.063
3/4"	26.9	60	0.083
1"	33.7	60	0.120
1 1/4"	42.4	80	0.211
1 1/2"	48.3	80	0.256
2"	60.3	100	0.440
2 1/2"	76.1	100	0.690
3"	88.9	120	1.160
4"	114.3	120	1.477

Dimensions in mm

This data sheet is designed as a guide and should not be regarded as wholly accurate in every detail. We reserve the right to amend the specification of any product without notice.

WN

Weld Nipple

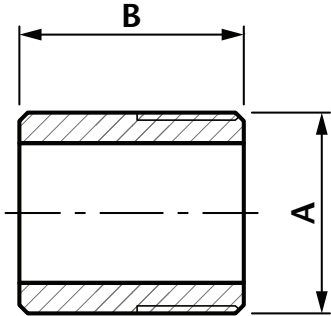

DN	A	B	Kgs
1/8"	10.2	30	0.010
1/4"	13.5	30	0.016
3/8"	17.2	30	0.020
1/2"	21.3	35	0.037
3/4"	26.9	40	0.057
1"	33.7	40	0.085
1 1/4"	42.4	50	0.118
1 1/2"	48.3	50	0.164
2"	60.3	50	0.0216
2 1/2"	76.1	60	0.422
3"	88.9	70	0.640
4"	114.3	80	1.033

RB

Hexagon Reducing Bush

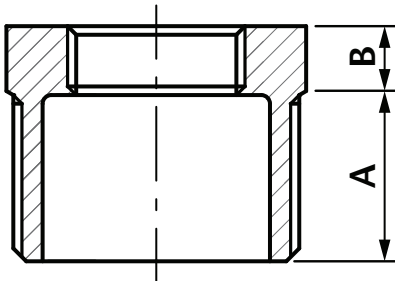

DN	A	B	Kgs
1/4" x 1/8"	12	6.5	0.013
3/8" x 1/4"	14	6.5	0.021
1/2" x 1/4"	16.5	7.5	0.035
1/2" x 3/8"	17	7	0.031
3/4" x 1/4"	18	8	0.065 NEW
3/4" x 3/8"	18	8	0.055 NEW
3/4" x 1/2"	18	8	0.048
1" x 1/2"	19	8	0.081
1" x 3/4"	19	8	0.067
1 1/4" x 1/2"	20.5	9	0.143
1 1/4" x 3/4"	20.5	9	0.141
1 1/4" x 1"	20.5	9	0.114
1 1/2" x 1/2"	22	9	0.200 NEW
1 1/2" x 3/4"	22	9	0.197
1 1/2" x 1"	22	9	0.176
1 1/2" x 1 1/4"	22	9	0.121
2" x 1"	26	9	0.328
2" x 1 1/4"	26	9	0.269
2" x 1 1/2"	26	9	0.228
2 1/2" x 2"	27	8	0.445
3" x 2"	33	11	0.795
3" x 2 1/2"	33	11	0.589
4" x 2"	36	12	1.492
4" x 3"	36	12	1.203

HN

Hexagon Nipple

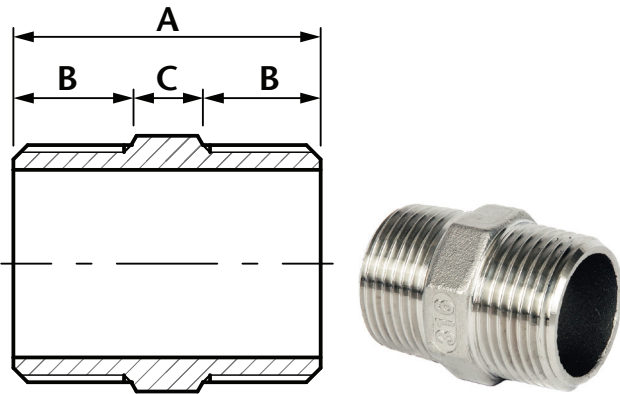

DN	A	B	C	Kgs
1/8"	30	12	6	0.016
1/4"	32	13	6	0.021
3/8"	36.5	15	6.5	0.035
1/2"	43	16.5	10	0.050
3/4"	45	18.5	8	0.070
1"	48	18.5	11	0.119
1 1/4"	53	20.5	12	0.180
1 1/2"	55.5	22.5	10.5	0.217
2"	64	25.5	13	0.328
2 1/2"	76	31	14	0.661
3"	80	33	14	0.855
4"	86	36	14	1.327

RHN

Reducing Hexagon Nipple

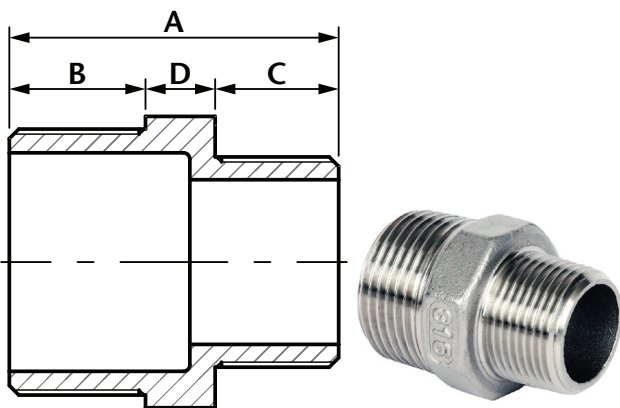

DN	A	B	C	D	Kgs
1/4" x 1/8"	30	13	11	6	0.017
3/8" x 1/4"	35	15	13	7	0.032
1/2" x 1/4"	39	17	14	8	0.045
1/2" x 3/8"	41	17	14	10	0.047
3/4" x 1/2"	43.5	18	17	8.5	0.074
1" x 1/2"	47	18.5	17	11.5	0.106
1" x 3/4"	48	18.5	18	11.5	0.105
1 1/4" x 1/2"	49.5	21	17	11.5	0.159
1 1/4" x 3/4"	51	21	18	12	0.153
1 1/4" x 1"	52	21	19.5	11.5	0.174
1 1/2" x 3/4"	52.3	22	18	12.3	0.220
1 1/2" x 1"	53	22	19	12	0.213
1 1/2" x 1 1/4"	55	22	21	12	0.217
2" x 1"	57.7	26	19	12.7	0.323
2" x 1 1/4"	60.5	26	21.5	13	0.322
2" x 1 1/2"	60.5	26	22	12.5	0.326
2 1/2" x 2"	70.5	30.5	26	14	0.606
3" x 2"	73	33	26	14	0.732
3" x 2 1/2"	77.5	33	30.5	14	0.824
4" x 2"	80.5	36	30.5	14	1.005
4" x 3"	83	36	33	14	1.187

Dimensions in mm

This data sheet is designed as a guide and should not be regarded as wholly accurate in every detail. We reserve the right to amend the specification of any product without notice.

SHP

Square Head Plug

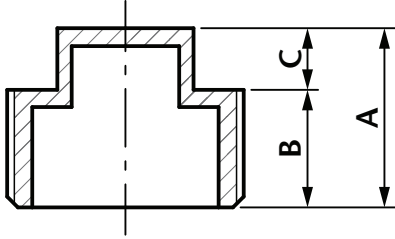

DN	A	B	C	Kgs
1/8"	11	6.7	4.3	0.005
1/4"	15.9	9.5	6.4	0.009
3/8"	16	10	6	0.012
1/2"	22.5	13.5	9	0.030
3/4"	24.5	14	10.5	0.039
1"	26	15	11	0.056
1 1/4"	29	18	11	0.082
1 1/2"	30	18	12	0.112
2"	36	22.5	13.5	0.160
2 1/2"	40	25	15	0.351
3"	42	27	15	0.424
4"	52	33	19	0.903

HHP

Hexagon Head Plug

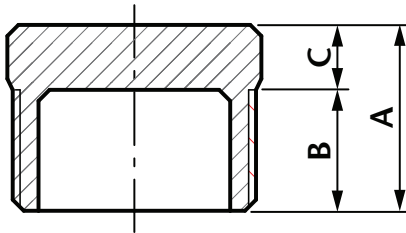

DN	A	B	C	Kgs
1/8"	16.5	10.5	6	0.009
1/4"	19	13	6	0.015
3/8"	19	13	6	0.022
1/2"	23	16	7	0.038
3/4"	25.5	17.5	8	0.056
1"	28.5	20	8.5	0.083
1 1/4"	30	21	9	0.125
1 1/2"	30.5	21	9.5	0.165
2"	35	26	9	0.259
2 1/2"	40	30	10	0.471
3"	44	33	11	0.597
4"	48.5	36	12.5	1.069

HB

Hexagon Backnut

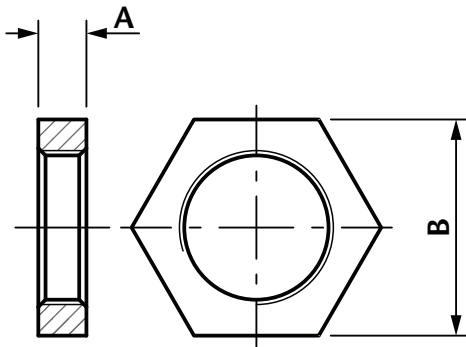

DN	A	B	Kgs
1/8"	6	18	0.007
1/4"	6.15	21	0.011
3/8"	7.15	26	0.021
1/2"	8	31	0.030
3/4"	9	35	0.036
1"	10	45	0.065
1 1/4"	11	54	0.103
1 1/2"	12	59	0.112
2"	13	74	0.203
2 1/2"	16	93.5	0.387
3"	19	106	0.500
4"	23	134	0.924

Dimensions in mm

This data sheet is designed as a guide and should not be regarded as wholly accurate in every detail. We reserve the right to amend the specification of any product without notice.

HA Hose Adaptor

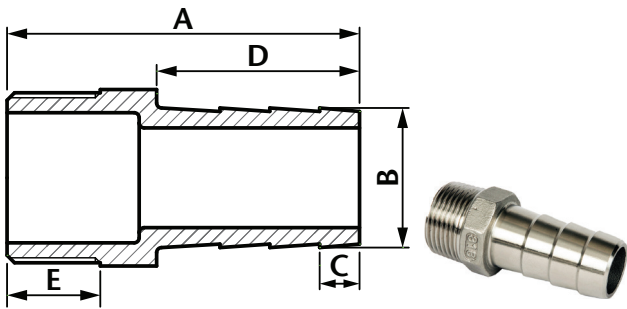

DN	A	B	C	D	E	Kgs
1/4"	42	9	7	23	12.8	0.021
3/8"	47.8	10	7.5	25	15	0.035
1/2"	60.5	15	8	35	17	0.060
3/4"	70	20.5	10	42.5	18	0.104
1"	82	27	12	52	19	0.175
1 1/4"	83	34	12	51	20.5	0.231
1 1/2"	90.4	40	13	57	21.5	0.311
2"	108	52.3	15.5	69.5	25.5	0.512
2 1/2"	132	65.5	20	87	30	0.900 NEW
3"	145	78	23.5	97	33	1.190 NEW
4"	154	103.5	24	104	36	1.700 NEW

RC Round Cap

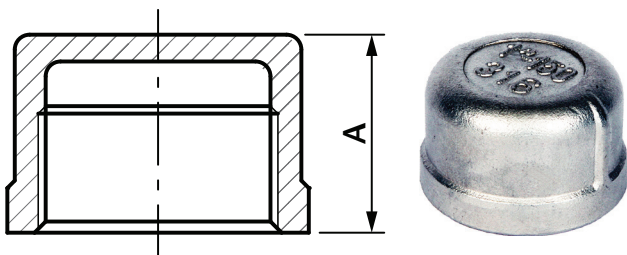

DN	A	Kgs
1/8"	15	0.008
1/4"	16	0.013
3/8"	16.5	0.017
1/2"	21	0.033
3/4"	22	0.048
1"	26	0.085
1 1/4"	28	0.127
1 1/2"	32	0.201
2"	33.5	0.286
2 1/2"	39	0.451
3"	42	0.670
4"	48.5	1.189



URS is a member of Registrar of Standards (Holdings) Ltd.
Certificate No. 1437B



URS is a member of Registrar of Standards (Holdings) Ltd.
Certificate No. 1437A

Distributor

Hydraulic Megastore
Unit 3, Estate Road 5
Grimsby, North East Lincolnshire
DN31 2TG

www.hydraulicmegastore.com